



**LEAR JET  
STEREO**

40 CHANNEL GRS (CB) TRANSCEIVER  
SOFT TOUCH UP/DOWN CHANNEL SELECTOR  
LED DISPLAY  
PA/CB/CH9 SWITCH  
TX INDICATOR LIGHT  
ANL (AUTOMATIC NOISE LIMITER) CIRCUIT



**8835**

**OPERATION AND SERVICE MANUAL**

**CARRADY ELECTRONICS LIMITED**

18 Coldwater Road, Don Mills, Ontario M3B 1Y7 Phone (416) 449-5051

# CONTENTS

|                                      | PAGE       |
|--------------------------------------|------------|
| Canada DOC Regulations .....         | 1          |
| U.S.A. FCC Regulations .....         | 1          |
| Description .....                    | 2          |
| <b>Operation Manual</b>              |            |
| Controls and indicators .....        | 3          |
| Receiving .....                      | 4          |
| Transmitting .....                   | 4          |
| The PA (Public Address) .....        | 5          |
| <b>Installation Manual</b>           |            |
| Mechanical installation .....        | 6          |
| Electrical connections .....         | 6          |
| Noise suppression .....              | 8          |
| Available GRS (CB) frequencies ..... | 8          |
| Specifications .....                 | 9          |
| <b>Service Manual</b>                |            |
| Warning .....                        | 10         |
| PLL Circuit alignment .....          | 10         |
| Alignment of Transmitter .....       | 11         |
| Alignment of Receiver .....          | 12         |
| Schematic Diagram .....              | 13         |
| Parts layout, main PCB .....         | Centerfold |

## **CANADA-D.O.C. REGULATIONS**

---

The federal Department of Communications (DOC) is responsible for the management and proper use of all radio communications services in Canada. It has prepared a handbook: "The new General Radio Service Handbook" to help you derive maximum benefit and enjoyment from GRS. You may obtain it by getting in touch with any Regional Headquarter or District Offices of the Department of Communication. Licensing is so important that the Radio Act requires that each GRS set you possess or operate must have its own license. Violation of these provisions are punishable by a fine of up to \$2,500 or imprisonment. To obtain a GRS License you must fill out a form 16-855, contained in the free brochure entitled "Obtaining Your License." A copy may be obtained from the dealer that sold you the equipment, your nearest DOC district office, or directly from the GRS Licensing Centre (General), Postal Station D-Box 2798, Ottawa, Ont. K1P 6H4.

## **U.S.A.-F.C.C. REGULATIONS**

---

This model is designed to operate under FCC Rules and Regulations Part 95. Operation of this unit is not permitted until you have obtained the necessary FCC license. This Class D Citizen Band License may be obtained by any citizen over 18 years of age by filling out FCC license application form 505. You are required to read and understand the applicable FCC rules and regulations. These can be obtained from the Superintendent of Documents, Government printing Office, Washington 25, D.C., requesting Volume VI of FCC Rules and Regulations (which includes Part 95). When you sign the application form you certify that you have read the rules and regulations. When you receive your license, you are required to fill out the Transmitter Identification card, FCC Form 452-C (available from your Dealer) and affix the card to the unit.

## **DESCRIPTION**

---

Your Lear Jet Stereo model 8835 is a solid state 2-way radio transceiver for mobile operation. A Frequency Synthesizer circuit provides 40 channel controlled PLL transmit and receive channels in the 27 MHz Band. Engineered for trouble-free operation, it uses heat resistant transistors in all critical areas. Current drain is exceptionally low, allowing relatively long operation even with the vehicle engine turned off.

### **The receiver**

The receiver employs a sensitive and highly selective dual conversion superheterodyne system with crystal-controlled PLL operation on all 40 channels. One of the features, designed to provide optimum reception, is an effective full time switchable ANL (Automatic Noise Limiter) in the audio stage. A ceramic filter provides sharp selectivity and high adjacent channel rejection.

A variable squelch control is incorporated to silence the receiver when no signals are being received. The squelch circuit is adjustable providing varying degrees of sensitivity to incoming signals.

### **The transmitter**

The transmitter features crystal-controlled operation on all 40 GRS (CB) channels. It employs high-efficiency transistors and low loss components, thus providing the maximum legal limit of RF power output.

# OPERATION MANUAL

## CONTROLS AND INDICATORS

---

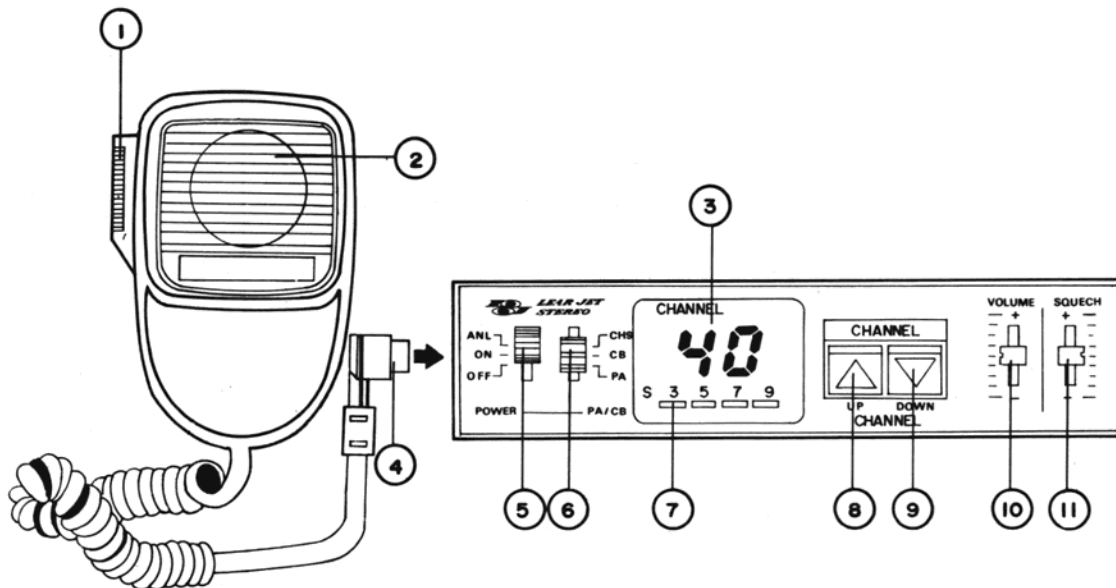

Figure 1

1. Push to talk button
2. Microphone
3. LED channel indicator
4. Microphone plug
5. OFF/ON/ANL switch
6. CH9/CB/PA switch
7. RF Signal (receive) and Audio Modulation (transmit) level indicator
8. UP scan button
9. DOWN scan button
10. Volume control
11. Squelch control

## RECEIVING

---

- Select a channel by pushing either the UP or DOWN scan buttons (9 or 8). The LED indicator (3) will show the number of the channel you are tuned in.
- Adjust the VOLUME control (10) to a comfortable listening level.

### **Squelch control (11)**

- The squelch control eliminates annoying background noise in the absence of signals. To properly adjust the squelch control, turn the volume up until a background noise is heard. Slowly adjust the Squelch control up or down until the background noise just disappears. At this point the receiver will be quiet under a no-signal condition. However, a reasonably strong incoming signal will overcome the squelch action and be heard. As the control is advanced, the squelch action is progressively increased and stronger incoming signals are needed to overcome it.
- To receive weak signals or to disable the squelch circuit, set the squelch control all the way down.

### **ANL (Automatic Noise Limiter) (5)**

- Turn the Automatic Noise Limiter ON to reduce impulse noise caused by your vehicle ignition system or other interferences.

### **RF signal level indicator (7)**

- When receiving, this meter provides a relative indication of signal strength in "S" (strength) units (from S3 to S9) providing a means of comparison between a received signal and another.

## TRANSMITTING

---

### **License**

- As explained before, prior to operating the transmitter, you must obtain the proper license which applies to your Country.

### **Antenna and Power source**

- Make sure that a **properly tuned** antenna is correctly installed and connected. (See **INSTALLATION MANUAL.**)

### **Microphone**

- Make sure that the microphone plug is properly connected to the socket on the side of the set.

### **Channel selector (8 and 9)**

- Select a channel by pushing either the UP or DOWN scan buttons. The LED channel indicator (3) will show the number of the channel you are tuned in.

### **Channel 9 preset**

- Channel 9 is designated as the **HELP** channel for exclusive use by motorists in distress.

### **Calling**

- To transmit, firmly depress the push-to-talk button (1) located on the left hand side of the microphone. Hold the mike at a 45° angle about 1 to 2 inches from your lips and speak in a clear, normal voice.
- When you are transmitting, the receiver is silenced and reception is therefore impossible. To receive again, simply release the microphone push-to-talk button. In the same way, your signal cannot be heard by another station when that station is transmitting. To establish a conversation, each party must take turns.

### **RF audio modulation level indicators (7)**

- During transmission, the LED indicate audio modulation level. If the LED action is weak, you should speak louder or hold the microphone nearer. If all four LED's are on, you should do the opposite.

## **THE P.A. (PUBLIC ADDRESS) SYSTEM** \_\_\_\_\_

- Your GRS (CB) can also be operated as a Public Address system.
- For PA operation, your GRS must be connected to an external speaker. See the paragraph **Electrical Installation** in the **INSTALLATION MANUAL** section.
- When switched to P.A. position, the normal radio operation is disabled.
- The P.A. volume is controlled by the receiver volume control.

# INSTALLATION MANUAL

## MECHANICAL INSTALLATION

---

- Choose a location with a suitable mounting surface that will allow a firm support to the holding bracket and allow easy access to the GRS controls and sufficient clearance for plugging the microphone in.
- Using the enclosed self-tapping screws, fasten the GRS holding bracket to the mounting surface.
- Attach the GRS to the bracket using the two knurled securing screws at the sides.
- Tilt the unit to the most convenient angle before tightening the securing screws.
- Using the enclosed self-tapping screws, fasten the microphone holding bracket to any convenient location.

## ELECTRICAL CONNECTIONS

---

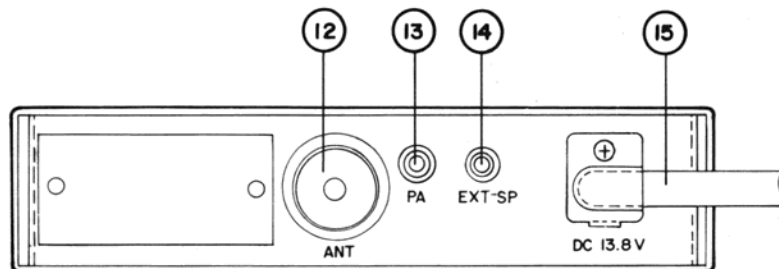

**Figure 2**

12. Antenna jack  
13. PA Speaker jack

14. External speaker jack  
15. DC 12V power cord

### DC power connection

- This transceiver can be operated with a 12 to 14 Volts DC negative or positive ground system. Connect the **RED** wire to the positive source and the **BLACK** wire to the negative source.

## **Antenna**

- Efficient mobile operation requires the best possible antenna. Many types are available, including trunk mount, bumper mount, roof top, mirror, etc. Selection is a matter of available space and personal preference; consult your dealer for his specific recommendation. All good antennas are packaged complete with hardware and connecting cable. Usually no tools are needed, although some mounting methods may require a small hole to be drilled. In general, a longer antenna performs best and the higher from the ground the better.
- The lead-in cable from the GRS (CB) antenna must be terminated with a PL-259 type male connector. Attach it to the matching antenna input connector at the rear of the unit.
- After a GRS antenna has been installed and connected to the transceiver, the antenna impedance must be accurately matched to the transmitter. Such alignment cannot be done without using a special meter. Only a qualified installer has the knowledge and instruments to properly match your CB to your CB antenna.

**DO NOT ATTEMPT TO TRANSMIT UNLESS A PROPERLY TUNED ANTENNA  
IS CONNECTED TO THE TRANSCEIVER.**

**OPERATING THE TRANSMITTER WITH AN UNMATCHED ANTENNA  
WILL RESULT IN SEVERE DAMAGE TO THE OUTPUT POWER CIRCUIT**

**WARRANTY WILL NOT COVER DAMAGES CAUSED  
BY A MISMATCHED ANTENNA**

## **PA (Public Address) speaker**

- Provision has been made for Public Address (P.A.) operation utilizing the microphone and audio stages on the transceiver. For PA operation, use preferably a high-efficiency public address horn type speaker with an impedance range of 8 to 16 Ohms. Connect the P.A. speaker to the jack marked PA in the rear of the unit using a 3.5 mm plug.

## **External speaker**

- If the installation of an external speaker is preferred, connect it to the jack marked "EXT SP" in the rear of the unit using a 3.5 mm plug. The speaker impedance should be in the range of 8 to 16 Ohms. Insertion of the plug, automatically silences the transceiver internal speaker.

## **NOISE ELIMINATION**

---

Your new GRS (CB) receiver has been tested for electrical noise rejection during manufacture. Electrical noise can be a vehicle system problem. Usually a 0.1 mfd capacitor on the generator or distributor will eliminate interference. Suppressors may be added to the spark plugs if noise persists. If the antenna cable is routed near the engine it will tend to pick up noise and care should be taken to route this cable away from the engine and ignition system. It is preferable to install the antenna as far as possible from the engine. If this does not help, see a professional installer or you Lear Jet Stereo dealer for assistance in noise suppression techniques and filter accessories.

## **AVAILABLE GENERAL RADIO SERVICE (CITIZEN BAND) FREQUENCIES**

---

Your transceiver provides operation on all available Canadian General Radio Service (GRS) and U.S. Citizens Band (CB) channels. Frequencies are listed in the accompanying table.

| <b>Channel</b> | <b>Frequency</b> | <b>Channel</b> | <b>Frequency</b> |
|----------------|------------------|----------------|------------------|
| 1              | 26.965           | 21             | 27.215           |
| 2              | 26.975           | 22             | 27.225           |
| 3              | 26.985           | 23             | 27.255           |
| 4              | 27.005           | 24             | 27.235           |
| 5              | 27.015           | 25             | 27.245           |
| 6              | 27.025           | 26             | 27.265           |
| 7              | 27.035           | 27             | 27.275           |
| 8              | 27.055           | 28             | 27.285           |
| 9              | 27.065           | 29             | 27.295           |
| 10             | 27.075           | 30             | 27.305           |
| 11             | 27.085           | 31             | 27.315           |
| 12             | 27.105           | 32             | 27.325           |
| 13             | 27.115           | 33             | 27.335           |
| 14             | 27.125           | 34             | 27.345           |
| 15             | 27.135           | 35             | 27.355           |
| 16             | 27.155           | 36             | 27.365           |
| 17             | 27.165           | 37             | 27.375           |
| 18             | 27.175           | 38             | 27.385           |
| 19             | 27.185           | 39             | 27.395           |
| 20             | 27.205           | 40             | 27.405           |

## SPECIFICATIONS

---

### Transmitter section

Power Output ..... 4 Watts Max (@13.8V DC)  
Emission ..... AM (6A3)  
Modulation ..... AM, 90% typical

### Receiver section

Circuit type ..... Dual conversion superheterodyne with RF stage and  
455 KHz ceramic filter  
Frequency ..... 1 crystal-controlled P.L.L. 40 channels in the 27 MHz  
Sensitivity ..... 1.0 $\mu$ V for 10dB S/N  
Squelch range ..... 0-1 mV  
Selectivity ..... 70 dB down at  $\pm$  10 KHz  
Intermediate Frequency (IF) ..... 1st I.F.: 10,695 MHz  
2nd I.F.: 455 KHz  
Image rejection ..... 55 dB  
Audio output ..... 3.5 W maximum at 8 Ohm load  
Current drain (receiving, squelch on) ..... 200 mA  
Current drain (transmit, max modulation) ..... 1,500 mA  
Antenna ..... nominal 50 Ohms impedance  
Power Source ..... nominal 12.6 Volts D.C.  
negative or positive ground  
(with polarity protector)  
Dimensions (overall) ..... 14.5(W)  $\times$  18.5(D)  $\times$  5(H) cm.  
Weight ..... 1,350 gr.

## SERVICE MANUAL

The technical information, diagrams and charts provided in this manual are supplied for the use of a qualified technician. It is the user's responsibility to see that this unit is operating at all times in accordance with rules and regulation of the Country where its use is intended.

### WARNING

---

As prescribed in Part 95.58, paragraph "E" of the FCC Rules and Regulations, the manufacturer is required to issue the following warnings:

1. Certain repairs and adjustments to this transceiver may be made legally only by a person in possession of a valid First or Second Class FCC Radiotelephone Operators License or by a person under the direct supervision of a holder of such a license. This applies particularly to those repairs or adjustments, such as replacement of crystals and transmitter oscillator components, which might affect the transmitter ability to comply with FCC/DOC regulations.
2. Use only approved replacement parts when servicing the transmitter. The use of a component (such as a crystal, semiconductor, capacitor, etc.) having different electrical characteristic and rating than that originally used could result in a violation of the FCC/DOC Regulations and is therefore prohibited.

#### Protective cover

To remove the cabinet cover, turn the Transceiver over (speaker grille upward) and remove the screws which fasten it to the main cabinet. The speaker is connected by two leads to the main chassis, be careful not to damage this wires.

### P.L.L. CIRCUIT ALIGNMENT

---

1. Connect a frequency counter to pin 10 of IC3 (C5121), the instrument should read 10.24 MHz  $\pm$  100 Hz.

#### VCO (Voltage Controlled Oscillator) alignment

1. Connect either a 50 Ohm dummy load or a Wattmeter to the antenna terminal.
2. Set the radio to channel 40 and in transmit mode.
3. Connect a Voltmeter between VCO test pin and ground.
4. Adjust LX8 to obtain +3.2V DC.
5. Set the radio to channel 1 and in receive mode.
6. Check to see the DC voltage dropping to a level between 1.0 to 1.5 volt DC. As long as the DC level stays between 3.2V DC for transmit at Channel 40 and 1.0 to 1.5 DC for receive at Channel 1, the VCO is set properly. The magnitude of the T.P1 voltage swing is determined by C69 at factory.

## **ALIGNMENT OF TRANSMITTER**

---

### **RF Driver alignment**

1. Select channel 19.
2. Connect an oscilloscope to the base of Q11.
3. Adjust LX17 for maximum amplitude of scope display (27.185 MHz).
4. Connect the scope to the collector of Q12.
5. Adjust LX18 for maximum amplitude on scope display.

### **RF Power Amplifier alignment**

1. Adjust the power supply voltage to 13.8 V and set the CB on channel 19.
2. Connect a Wattmeter to the antenna connector.
3. Adjust LX19 and LX20 and readjust LX18 and LX17 for maximum power indication.
4. When all coils are peaked, the power meter should indicate above 4.0 Watts.
5. Set the CB on channel 1. Without disturbing LX19 and LX20, turn LX18 clockwise until the Output Power Meter reads 3.7 Watts.
6. Set the CB on channel 40. Turn LX17 counter-clockwise until the Output Power Meter reading drops below 3.5 Watts.
7. Recheck the Output Power Meter reading on channels 1 and 40, if it exceeds 3.7 Watts, repeat steps 5 and 6.

### **Transmit Frequency check**

1. Set the CB on transmit mode with no modulation.
2. Connect a Frequency Counter to the antenna load or to the tab provided at the Wattmeter. The frequency should be within  $\pm 300$  Hz from each channel center frequency as tabulated in the frequency table.

### **Alignment of Modulation Sensitivity**

1. Set the CB on transmit mode and apply 20 mV, 1 KHz signal to the Microphone input circuit.
2. Adjust RV3 to obtain 85% modulation at this condition.
3. Next, decrease the signal input to 3 mV and observe that the modulation ratio is keeping the value higher than 60%.

## **ALIGNMENT OF RECEIVER**

---

### **Sensitivity alignment**

1. Set the Signal Generator at 27.185 MHz, 1 KHz and 30% modulation.
2. Set the CB on channel 19.
3. Adjust HT 101, 102, 103, 104, 105 and LX16 for maximum audio output across the 8 Ohm dummy load resistor. To avoid inaccurate alignment due to AGC action, this alignment should be performed by gradually decreasing the Signal Generator output signal to the minimum level required for tuning.

### **Squelch Circuit Alignment**

1. Set the Signal Generator to provide RF input signal of 54 dB (1 KHz, 30% modulation).
2. Rotate the Squelch control fully clockwise.
3. Adjust RV2 for squelch action.

### **Signal Meter adjustment**

1. Set the Signal Generator to provide 40 dB signal output.
2. Adjust RV1 so that the Signal Meter LED "9" in the front panel illuminates.

# PARTS LAYOUT, MAIN PCB

